

GLASS Door clamps

K1750 (up to 50, 80 or 120kg)

- For two glass doors with simultaneous opening and closing (synchronised)
- Suitable for glass panels 8–12mm thick
- Available with optional side-mounting (face fix) brackets
- Increased wear resistance and durability
- **Die cast alloy roller body.** Delrin covered wheels and ball race bearing
- Upper sliding movement, leaving the lower section free
- Adjustment: **the stop brake is adjustable** according to the door's weight

Please specify part K1750/50 for doors up to 50kg.
 Please specify part K1750/80 for doors up to 80kg.
 Please specify part K1750/120 for doors up to 120kg.

2m lengths of track are stocked as standard
 (3m for 120kg kit). Other lengths available upon request.

For side-mounting (face fixing) please request brackets to suit
 (1 per 40cm track).

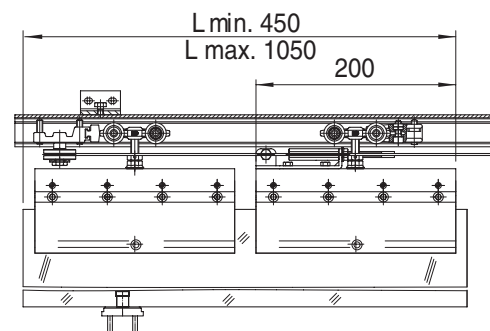
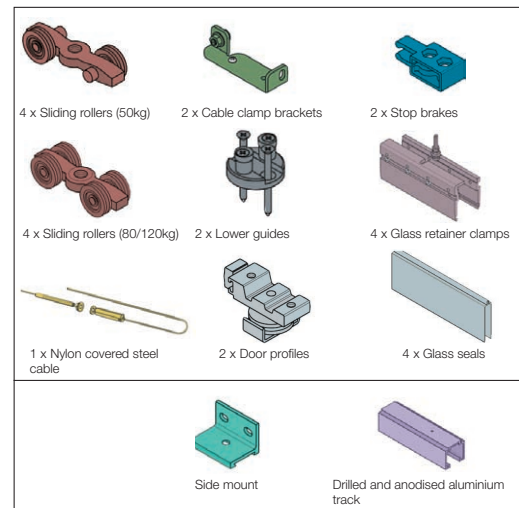
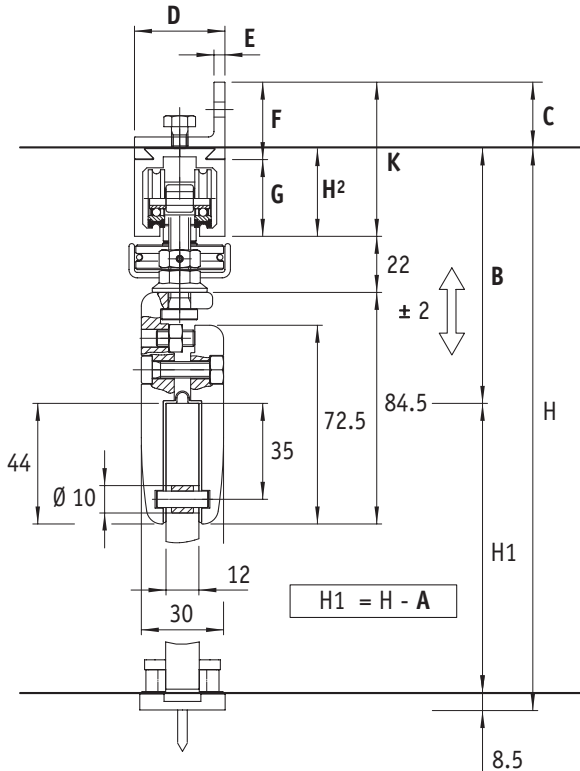
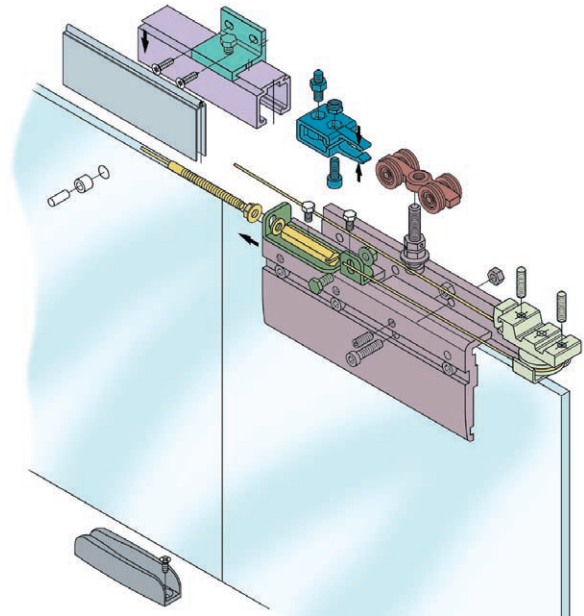

SYSTEM	A	B	C	D	E	F	G	H ²	K
1750/50	99.5	91	23	32	3	25.5	27	29.5	52.5
1750/80	99.5	91	23	32	3	25.5	27	29.5	52.5
1750/120	102	93.5	24	33	4	28	28	32	56