

RAVEN RP85 Magnetic seals

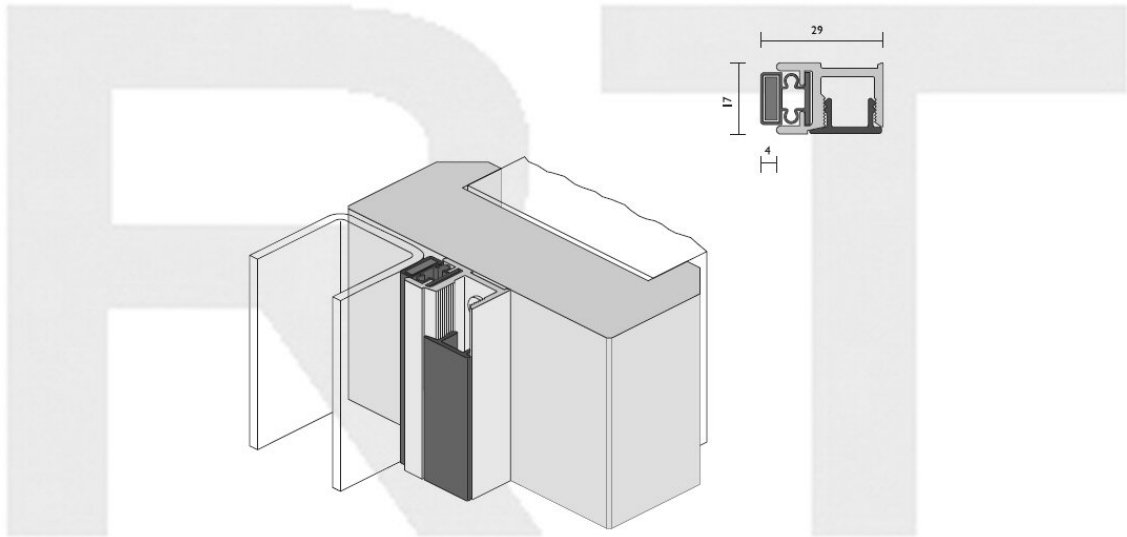

RP85

(M)

A magnetic seal that is fixed to the head and jambs as a door stop where steel clad doors are used. For timber doors, a thin steel strip can be attached to the door face. The magnetic strip has sufficient closing strength that latches are not required.

Location Head and jamb for single and double broad butt hinged doors.

Min/Max Gap 0–4mm (user determined).

Seal Sizes 2250mm stock lengths

Standard Finish Anodised Satin Clear.

Used in conjunction Door bottom seals and astragal seals. Note: If fixing to rebated frames of single doors, specify a large backset door latch.



Royde & Tucker Ltd

Bilton Road

Cadwell lane

Hitchin

SG4 0SB

Tel:01462 444444

Fax:01462 444433

www.ratman.co.uk

e-mail: sales@ratman.co.uk