

## RAVEN RP63 Intumescent, fire and smoke seal

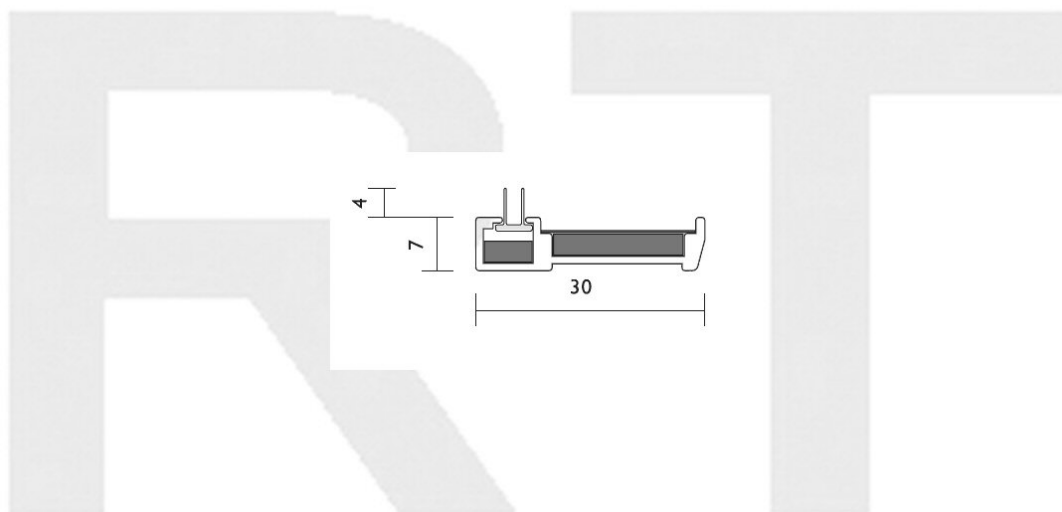

RP63

(H)

A combined intumescent smoke and fire seal which is heat activated. It is unobtrusively set into a machined groove (30x7mm) around perimeter of timber frame or door edges. The smoke seal is achieved by a pair of silicon fins that seal between the door and the frame. Dependent on application, fire ratings of one to two hours have been certified by fire door manufacturers using RP63 intumescent fire and smoke seal.

Location Morticed into the door or frame around stiles and head.

Min/Max Gap 2 to 3mm.

Size Available in 2100mm stock lengths.

Fixing Method Adhesive (by installer).

Standard Finish Anodised Aluminium Satin Clear.

Used in conjunction Raven Si rated door bottom smoke seals, or nylon brush strip seals for pivot doors.

**Royde & Tucker Ltd**

Bilton Road

Cadwell lane

Hitchin

SG4 0SB

Tel:01462 444444

Fax:01462 444433

[www.ratman.co.uk](http://www.ratman.co.uk)

e-mail: [sales@ratman.co.uk](mailto:sales@ratman.co.uk)

