

RAVEN RP39 Magnetic seals

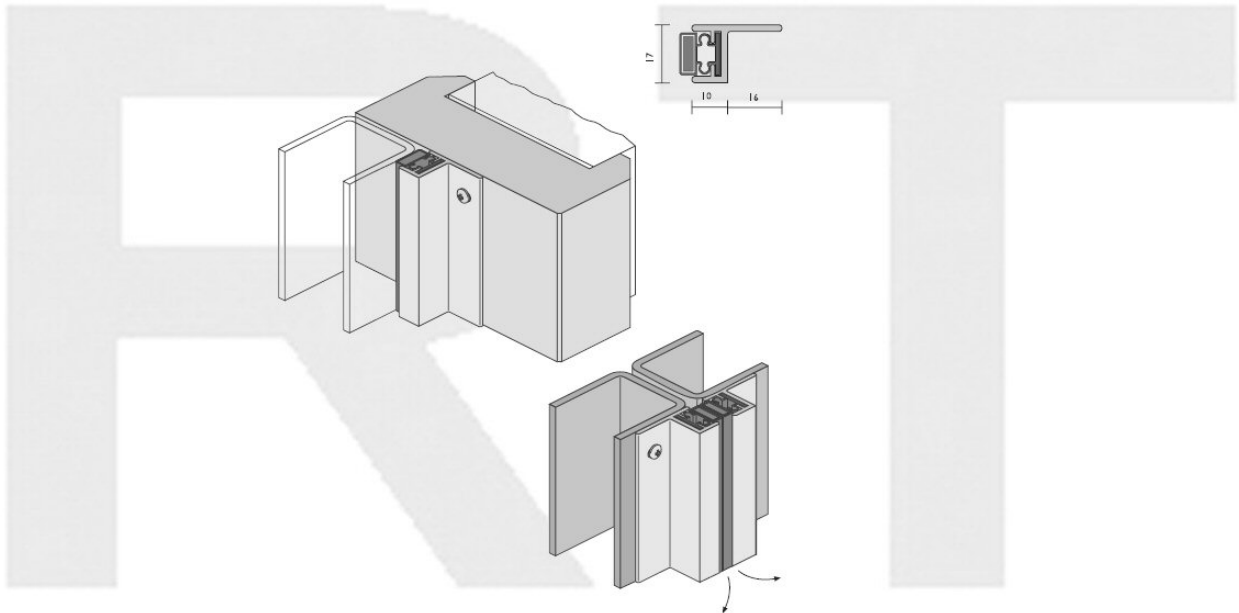

RP39

(M)

A refrigeration type vinyl magnetic strip in an anodised aluminium housing, which provides a very tight seal for steel clad doors and jambs, and may be used as a stop. For timber doors, a thin steel strip can be attached to the door face. The magnetic strip has sufficient closing strength that latches are not required. It can also be used in pairs on meeting stiles of timber doors.

Location Single or double doors, sliding doors and stiles, heads and jambs or bulk head applications. Butt hinges recommended.

Min/Max Gap 4mm to 8mm (meeting stiles).

Standard Finish Anodised Satin Clear.

Seal Sizes 2250mm stock lengths

Used in conjunction Door bottom seals.

Note: As an astragal seal, RP39 is not recommended for highly active doors, i.e. it is best suited to infrequent use and door closer hold-open applications.

Royde & Tucker Ltd

Bilton Road

Cadwell lane

Hitchin

SG4 0SB

Tel:01462 444444

Fax:01462 444433

www.ratman.co.uk

e-mail: sales@ratman.co.uk

