

RAVEN RP16Si Astragal/meeting stile seals

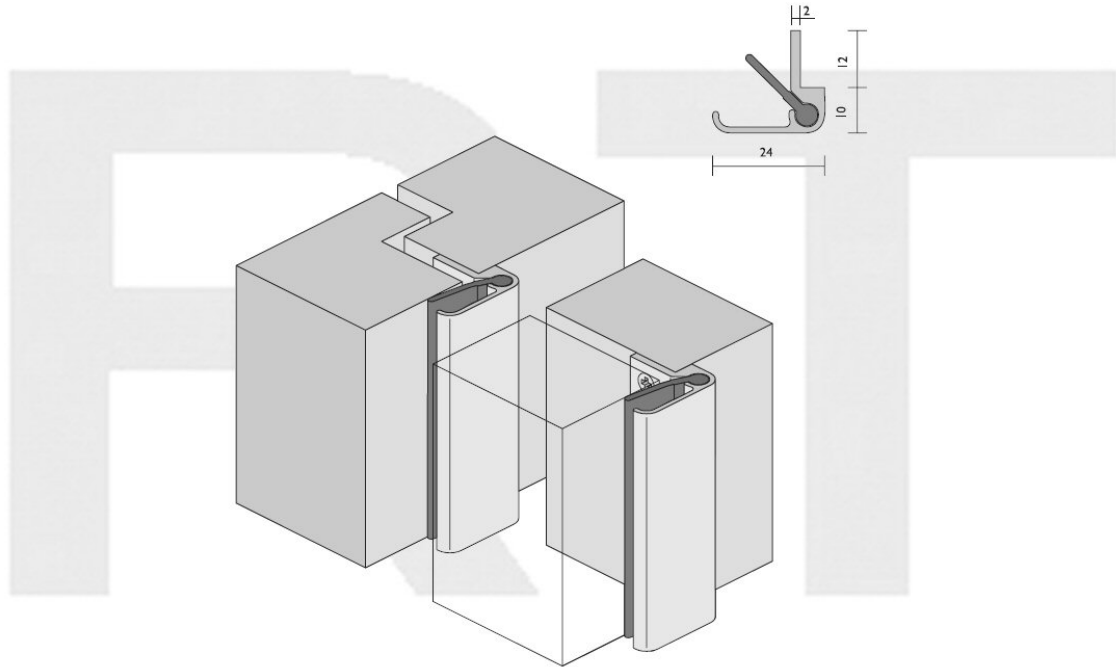

RP16Si

(M)

A medium temperature smoke and acoustic astragal seal for use with plain or rebated meeting stiles on double doors. The aluminium trim cleanly conceals the sealing portion of the seal. If necessary the leg of the aluminium can be cut out (checked) to allow for any locks and latches. It is used where only one door leaf is active. The seal also improves security and when two are fitted (one on each leaf), noise infiltration is greatly reduced.

Location Meeting stiles of double doors, butt hinged.

Min/Max Gap 2.5mm/8mm.

Seal Sizes 2250mm or 2500mm stock sizes.

Standard Finish Anodised Satin Clear.

Royde & Tucker Ltd

Bilton Road

Cadwell lane

Hitchin

SG4 0SB

Tel:01462 444444

Fax:01462 444433

www.ratman.co.uk

e-mail: sales@ratman.co.uk

